

EK Series – Finned Tube Bundle Shell & Tube Water to Oil Cooling

The EK Series – the ‘Green’ cooler – is the most efficient heat exchanger offered in the water-cooled series. The aluminum finned tube bundle design provides an increased surface area that allows for optimal heat rejection with low water usage. An optional Surge-Cushion® bypass is available for cold start up protection or flow surges. Sea water service options are also available. The low cost, compact design is ideal for general purpose hydraulic power unit installations.

TTP’s XSelector sizing program can help dial in sizing to optimize water usage.

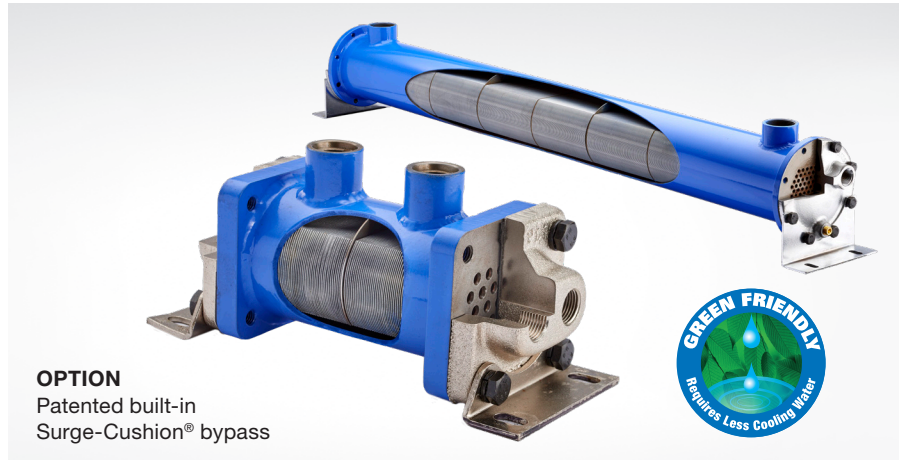

How to Order

Model Series

- EK** = NPT Shell Side connections x NPT Tube Side connections.
- EKS** = SAE O-Ring Shell Side connections x NPT Tube Side connections.
- EKM** = BSPP Shell Side connections x BSPP Tube Side connections.
- EKF** = SAE 4 Bolt Flange (Tapped SAE) Shell Side connections x NPT Tube Side connections.
- EKFM** = SAE 4 Bolt Flange (Tapped Metric) Shell Side connections x BSPP Tube Side connections.

Model Size Selected

- 505, 508, 510, 512, 514, 518, 524, 536, 708, 712, 714, 718, 724, 736, 1012, 1014, 1018, 1024, 1036, 1048**
- (See Performance Curve Chart on pages 3-5 for sizes or **XSelector*** sizing program)

Baffle Spacing

- Blank** - 500, 700, 1012, and 1014
- EK-1036** - 6 or 9 & **EK-1048** - 6 or 8
- (Baffle spacing is dependent on applicable sizes found in sizing charts on pages 3-5 or can be determined by using **XSelector*** sizing program)

Tubeside Passes

- O** - One Pass
- T** - Two Pass
- F** - Four Pass

Surge Cushion

- Blank** - None
- R** - Surge Cushion

Cooling Tube Material

- Blank** - Copper
- CN** - Copper Nickel

Tubesheet Material

- Blank** - Steel
- W** - Copper Nickel

End Bonnet Material

- Blank** - Cast Iron
- NP** - Electroless Nickel Plate

Optional Surge-Cushion®

The **Surge-Cushion®** is a patented protective device designed to internally bypass a portion of the oil flow during cold start conditions, or when sudden flow surges temporarily exceed the maximum flow allowed for a given cooler. This device may replace an external bypass, but it is not intended to bypass the total oil flow.

Features

Compact size

Interchangeable with TTP K series

3/16" tube size

High pressure ratings

Cooling Tube Side Material Options

- Standard Steel
- Copper Nickel

Multiple Connection Options

- NPT x NPT
- SAE Code 61 x NPT
- SAE x NPT
- SAE Code 61 x BSPP

End Bonnets Removable For Servicing

Mounting Feet Included (May be rotated in 90° increments)

Sea water applications, end model code with CN-W-NP**

Materials

Tubes Copper/Copper Nickel

Tubesheet Steel/Copper Nickel

Shell Steel

Baffles Steel

End Bonnets Cast Iron/

Electroless Nickel Plate

Mounting Brackets Carbon Steel

Gaskets Nitrile Rubber/
Cellulose Fiber

Nameplate Aluminum Foil

Ratings

Maximum Operating Pressure - Shell Side 500 PSI

Maximum Operating Pressure - Tube Side 150 PSI

Maximum Operating Temperature 250°F

Heat removal up to 400 HP (300 KW)

Oil flow rates up to 80 U.S. GPM (300 L/MIN)

Maximum viscosity - 150 cSt

* To register for **XSelector** please go to www.thermaltransfer.com/get-in-touch/ and complete the **XSelector** Inquiry form and submit.

Download the **XSelector** for both Apple and Android formats by searching for **XSelector** in their App Stores. You must first register for **XSelector** before using it on mobile devices.

** For Salt Water applications a Zinc Anode needs to be plumbed in the water inlet of the cooler to prevent corrosion.

Selection Procedure

Performance Curves are based on 100SSU oil leaving the cooler 40°F higher than the incoming water temperature (40°F approach temperature).

STEP 1 Determine the Heat Load. This will vary with different systems, but typically coolers are sized to remove 25 to 50% of the input nameplate horsepower. (Example: 100 HP Power Unit x .33 = 33 HP Heat load.)

$$\text{If BTU/HR is known: } \text{HP} = \frac{\text{BTU/HR}}{2545}$$

STEP 2 Determine Approach Temperature.

$$\text{Desired oil leaving cooler } ^\circ\text{F} - \text{Water Inlet temp. } ^\circ\text{F} = \text{Actual Approach}$$

STEP 3 Determine Curve Horsepower Heat Load. Enter the information from above:

$$\text{HP heat load} \times \frac{40}{\text{Actual Approach}} \times \text{Viscosity Correction A} = \text{Curve Horsepower}$$

STEP 4 Enter curves at oil flow through cooler and curve horsepower. Any curve above the intersecting point will work.

STEP 5 Determine Oil Pressure Drop from Curves. Multiply pressure drop from curve by correction factor B found on oil viscosity correction curve.

$$l = 5 \text{ PSI} \quad n = 10 \text{ PSI} \quad s = 20 \text{ PSI}$$

Oil Temperature

Oil coolers can be selected by using entering or leaving oil temperatures.

Typical operating temperature ranges are:

Hydraulic Motor Oil	110°F - 130°F
Hydrostatic Drive Oil	130°F - 180°F
Lube Oil Circuits	110°F - 130°F
Automatic Transmission Fluid	200°F - 300°F

Desired Reservoir Temperature

Return Line Cooling: Desired temperature is the oil temperature leaving the cooler. This will be the same temperature that will be found in the reservoir.

Off-Line Recirculation Cooling Loop: Desired temperature is the temperature entering the cooler. In this case, the oil temperature change must be determined so that the actual oil leaving temperature can be found. Calculate the oil temperature change (Oil ΔT) with this formula:

$$\text{Oil } \Delta T = (\text{BTUs/HR}) / (\text{GPM Oil Flow} \times 210)$$

To calculate the oil leaving temperature from the cooler, use this formula:

$$\text{Oil Leaving Temperature} = \text{Oil Entering Temperature} - \text{Oil } \Delta T$$

This formula may also be used in any application where the only temperature available is the entering oil temperature.

Oil Pressure Drop: Most systems can tolerate a pressure drop through the heat exchanger of 20 to 30 PSI. Excessive pressure drop should be avoided. Care should be taken to limit pressure drop to 5 PSI or less for case drain applications where high back pressure may damage the pump shaft seals.

Maximum Flow Rates

Unit Size	Shell Side GPM	Tube Side GPM		
		One Pass	Two Pass	Four Pass
500	20	13	6	N/A
700	60	24	12	6
1000	80	56	28	14

Incorrect installation can cause premature failure.

Oil Viscosity Correction Multipliers

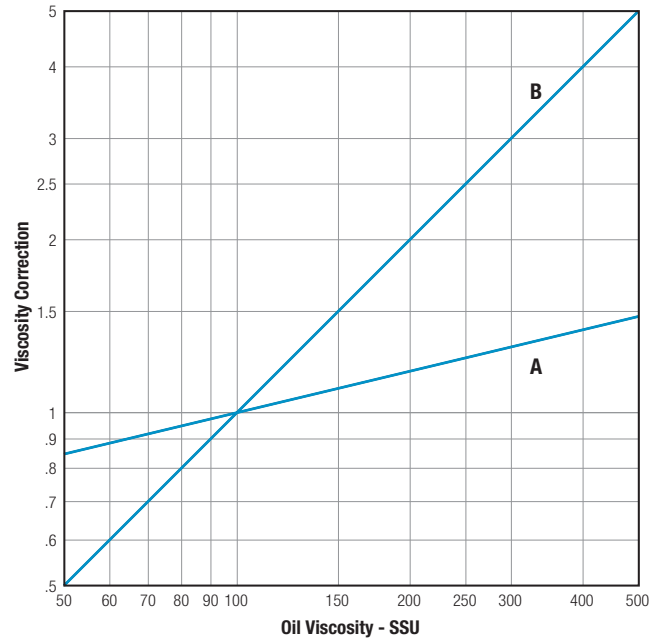

Recirculation Loop

Water Cooled Hydraulic Oil Coolers

Basis:

- 40°F Entering temperature difference (Maintain reservoir 40°F above the incoming water temperature)
- Heat removal 30% of input horsepower
- Hydraulic system flow (GPM) x 3 = Gallons; reservoir size
- 1 GPM cooler flow per HP heat to be removed
- Turn-over reservoir 3-4 times per hour
- Maximum flows

System Horsepower	HP Heat Load	Minimum Required GPM Oil Flow	Minimum Required GPM Water Flow	Heat Exchanger Model Number
3	.9	1	1	EK-505-T
5	1.5	2	1	
7.5	2.25	2	1	EK-512-T
10	3	3	1.5	
15	4.5	4.5	2	
20	6	6	3	
25	7.5	7.5	4	EK-712-T
30	9	9	4.5	
40	12	12	6	
50	15	15	7.5	EK-1012-T
60	18	18	9	
75	22.5	23	12	
100	30	30	15	

Performance Curves

For additional sizing information consider using TTP's **XSelector** online sizing Program.*

1:1 Oil to Water Ratio – High Water Usage

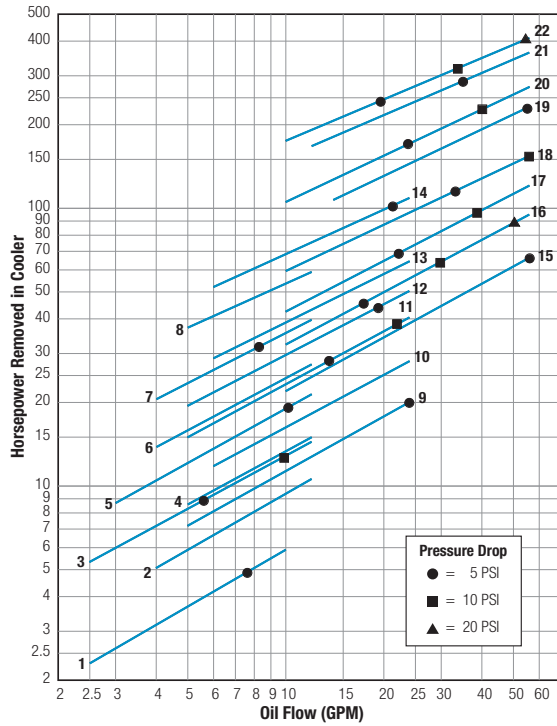

Curve Number	Model	Approximate Weight (LBS)	
		Net	Shipping
1	EK-505-0	6	7
2	EK-508-0	7	8
3	EK-510-0	8	9
4	EK-512-0	9	10
5	EK-514-0	10	11
6	EK-518-0	11	12
7	EK-524-0	13	14
8	EK-536-0	17	18
9	EK-708-0	15	16
10	EK-712-0	18	19
11	EK-714-0	19	20
12	EK-718-0	22	23
13	EK-724-0	26	28
14	EK-736-0	34	36
15	EK-1012-0	35	37
16	EK-1014-0	38	40
17	EK-1018-0	42	45
18	EK-1024-0	50	55
19	EK-1036-9-0	67	85
20	EK-1036-6-0	67	85
21	EK-1048-8-0	78	95
22	EK-1048-6-0	78	95

2:1 Oil to Water Ratio – Medium Water Usage

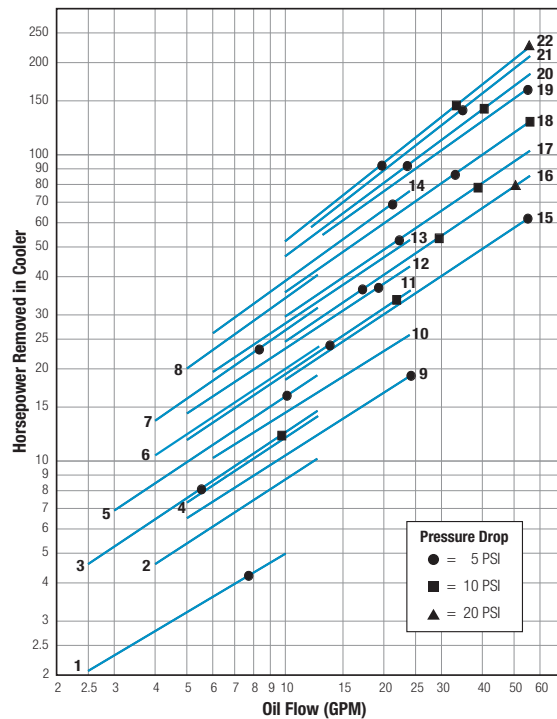

Curve Number	Model	Approximate Weight (LBS)	
		Net	Shipping
1	EK-505-T	6	7
2	EK-508-T	7	8
3	EK-510-T	8	9
4	EK-512-T	9	10
5	EK-514-T	10	11
6	EK-518-T	11	12
7	EK-524-T	13	14
8	EK-536-T	17	18
9	EK-708-T	15	16
10	EK-712-T	18	19
11	EK-714-T	19	20
12	EK-718-T	22	23
13	EK-724-T	26	28
14	EK-736-T	34	36
15	EK-1012-T	35	37
16	EK-1014-T	38	40
17	EK-1018-T	42	45
18	EK-1024-T	50	55
19	EK-1036-9-T	67	85
20	EK-1036-6-T	67	85
21	EK-1048-8-T	78	95
22	EK-1048-6-T	78	95

* To register for **XSelector** please go to www.thermaltransfer.com/get-in-touch/ and complete the **XSelector** Inquiry form and submit. Download the **XSelector** for both Apple and Android formats by searching for **XSelector** in their App Stores. You must first register for **XSelector** before using it on mobile devices.

Performance Curves

For additional sizing information consider using TTP's **XSelector** online sizing Program.*

4:1 Oil to Water Ratio – Low Water Usage

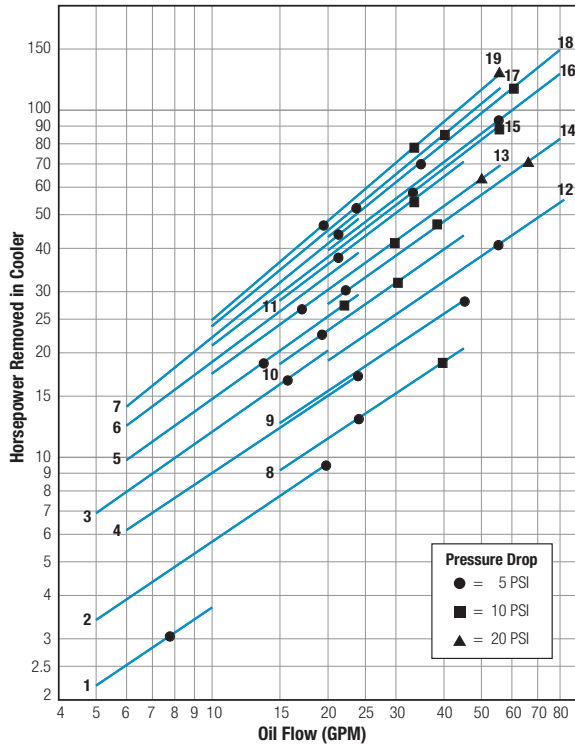

Curve Number	Model	Approximate Weight (LBS)	
		Net	Shipping
1	EK-505-T	6	7
2	EK-508-T	7	8
3	EK-518-T	11	12
4	EK-708-F	15	16
5	EK-714-F	19	20
6	EK-724-F	26	28
7	EK-736-F	34	36
8	EK-708-T	15	16
9	EK-712-T	18	19
10	EK-718-T	22	23
11	EK-736-T	34	36
12	EK-1012-T	35	37
13	EK-1014-T	38	40
14	EK-1018-T	42	45
15	EK-1024-T	50	55
16	EK-1036-9-T	67	85
17	EK-1036-6-T	67	85
18	EK-1048-8-T	78	95
19	EK-1048-6-T	78	95

7:1 Oil to Water Ratio – Lower Water

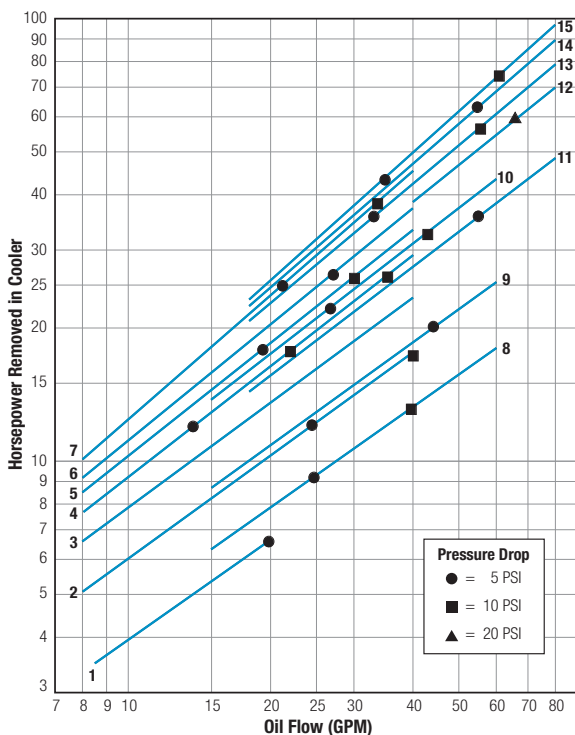

Curve Number	Model	Approximate Weight (LBS)	
		Net	Shipping
1	EK-508-T	7	8
2	EK-708-F	15	16
3	EK-712-F	18	19
4	EK-714-F	19	20
5	EK-718-F	22	23
6	EK-124-F	26	28
7	EK-736-F	34	36
8	EK-708-T	15	16
9	EK-712-T	18	19
10	EK-724-T	26	28
11	EK-1012-T	35	37
12	EK-1018-T	42	45
13	EK-1024-T	50	55
14	EK-1036-9-T	67	85
15	EK-1048-8-T	78	95

* To register for **XSelector** please go to www.thermaltransfer.com/get-in-touch/ and complete the **XSelector** Inquiry form and submit. Download the **XSelector** for both Apple and Android formats by searching for **XSelector** in their App Stores. You must first register for **XSelector** before using it on mobile devices.

Performance Curves

For additional sizing information consider using TTP's **XSelector** online sizing Program.*

10:1 Oil to Water Ratio – Lowest Water Usage

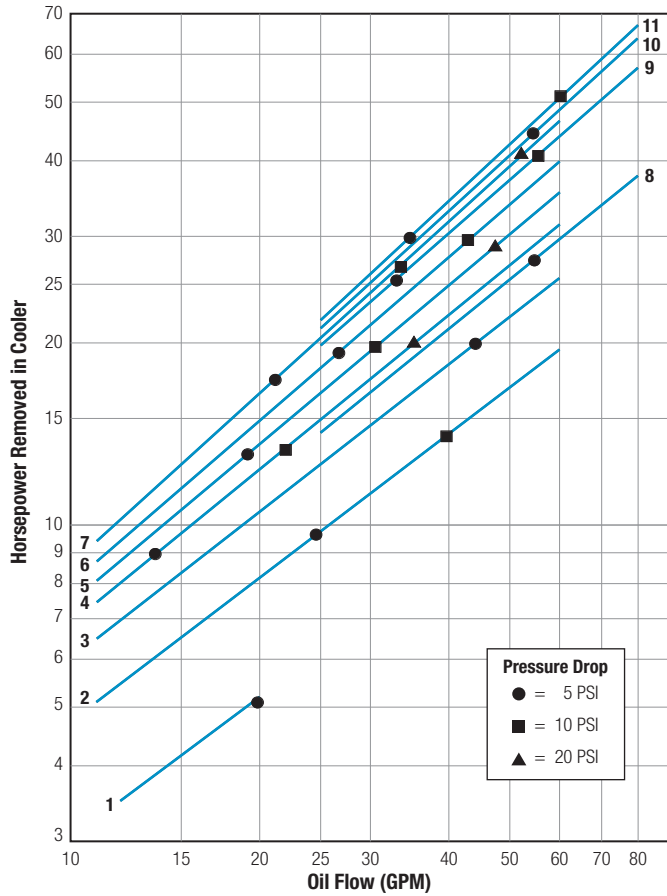

Curve Number	Model	Approximate Weight (LBS)	
		Net	Shipping
1	EK-508-T	7	8
2	EK-708-F	15	16
3	EK-712-F	18	19
4	EK-714-F	19	20
5	EK-718-F	22	23
6	EK-724-F	26	28
7	EK-736-F	34	36
8	EK-1012-F	35	37
9	EK-1014-F	50	55
10	EK-1036-9-F	67	85
11	EK-1048-8-F	78	95

* To register for **XSelector** please go to www.thermaltransfer.com/get-in-touch/ and complete the **XSelector** Inquiry form and submit. Download the **XSelector** for both Apple and Android formats by searching for **XSelector** in their App Stores. You must first register for **XSelector** before using it on mobile devices.

Dimensions

One Pass

For 3D models and spec sheets visit the EK product page on our website.
<https://www.thermaltransfer.com/product/ek-series>

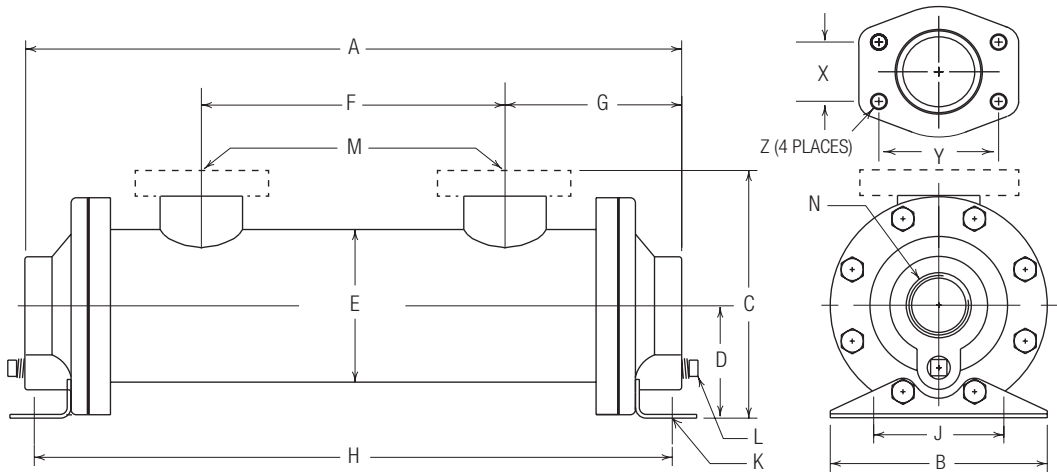

Flange Size	1 1/2	2
X	1.41	1.69
Y	2.75	3.06
EKF Z	1/2 - 13 UNC-2B	
EKFM Z	M-12	

Model	A	B Max. Width	C		D	E Diameter	F	G	H	J	K	L NPT BSPP	M				N NPT BSPP	
			NPT/BSPP/SAE	SAE Flange									NPT	SAE O-Ring	SAE Flange	BSPP		
EK-505	7.37	3.5	3.75	N/A	1.63	2.55	2.19	2.59	7.44	2.50	.34 x .62 Slot	N/A	1/2	- 8 3/4-16	N/A	1/2	3/4	
EK-508	10.37	3.5	3.90	N/A	1.62	2.55	3.85	3.26	10.44	2.50		N/A	3/4	- 12 1/16-12	N/A	3/4	3/4	
EK-510	12.37	3.5	3.90	N/A	1.62	2.55	5.85	3.26	12.44	2.50		N/A	3/4		N/A	3/4	3/4	
EK-512	14.37	3.5	3.90	N/A	1.62	2.55	7.85	3.26	14.44	2.50		N/A	3/4		N/A	3/4	3/4	
EK-514	16.37	3.5	3.90	N/A	1.62	2.55	9.85	3.26	16.44	2.50		N/A	3/4		N/A	3/4	3/4	
EK-518	20.37	3.5	3.90	N/A	1.62	2.55	13.85	3.26	20.44	2.50		N/A	3/4		N/A	3/4	3/4	
EK-524	26.37	3.5	3.90	N/A	1.62	2.55	19.85	3.26	26.44	2.50		N/A	3/4		N/A	3/4	3/4	
EK-536	38.37	3.5	3.90	N/A	1.62	2.55	31.85	3.26	38.44	2.50		N/A	3/4		N/A	3/4	3/4	
EK-708	11.13	5.0	5.47	5.71	2.59	3.52	3.00	4.07	10.39	3.00	.44 x 1.00 Slot	1/4	1 1/2		- 24 1 1/8-12	1 1/2	1 1/2	1 1/4
EK-712	15.13	5.0	5.47	5.71	2.59	3.52	7.00	4.07	14.39	3.00		1/4	1 1/2	1 1/2		1 1/2	1 1/4	
EK-714	17.13	5.0	5.47	5.71	2.59	3.52	9.00	4.07	16.39	3.00		1/4	1 1/2	1 1/2		1 1/2	1 1/4	
EK-718	21.13	5.0	5.47	5.71	2.59	3.52	13.00	4.07	20.39	3.00		1/4	1 1/2	1 1/2		1 1/2	1 1/4	
EK-724	27.13	5.0	5.47	5.71	2.59	3.52	19.00	4.07	26.39	3.00		1/4	1 1/2	1 1/2		1 1/2	1 1/4	
EK-736	39.13	5.0	5.47	5.71	2.59	3.52	31.00	4.07	38.39	3.00		1/4	1 1/2	1 1/2		1 1/2	1 1/4	
EK-1012	15.32	6.5	7.65	8.28	4.00	5.05	6.18	4.57	15.46	4.00		1/4	2	2		1 1/2	1 1/2	1 1/2
EK-1014	17.32	6.5	7.65	8.28	4.00	5.05	8.18	4.57	17.46	4.00		1/4	2	2		1 1/2	1 1/2	1 1/2
EK-1018	21.32	6.5	7.65	8.28	4.00	5.05	12.18	4.57	21.46	4.00	1/4	2	2	1 1/2	1 1/2	1 1/2		
EK-1024	27.32	6.5	7.65	8.28	4.00	5.05	18.18	4.57	27.46	4.00	1/4	2	2	1 1/2	1 1/2	1 1/2		
EK-1036	39.32	6.5	7.65	8.28	4.00	5.05	30.18	4.57	39.46	4.00	1/4	2	2	1 1/2	1 1/2	1 1/2		
EK-1048	51.32	6.5	7.65	8.28	4.00	5.05	42.18	4.57	51.46	4.00	1/4	2	2	1 1/2	1 1/2	1 1/2		

NOTE: All dimensions in inches. We reserve the right to make reasonable design changes without notice.

Dimensions

Two Pass

For 3D models and spec sheets visit the EK product page on our website.
<https://www.thermaltransfer.com/product/ek-series>

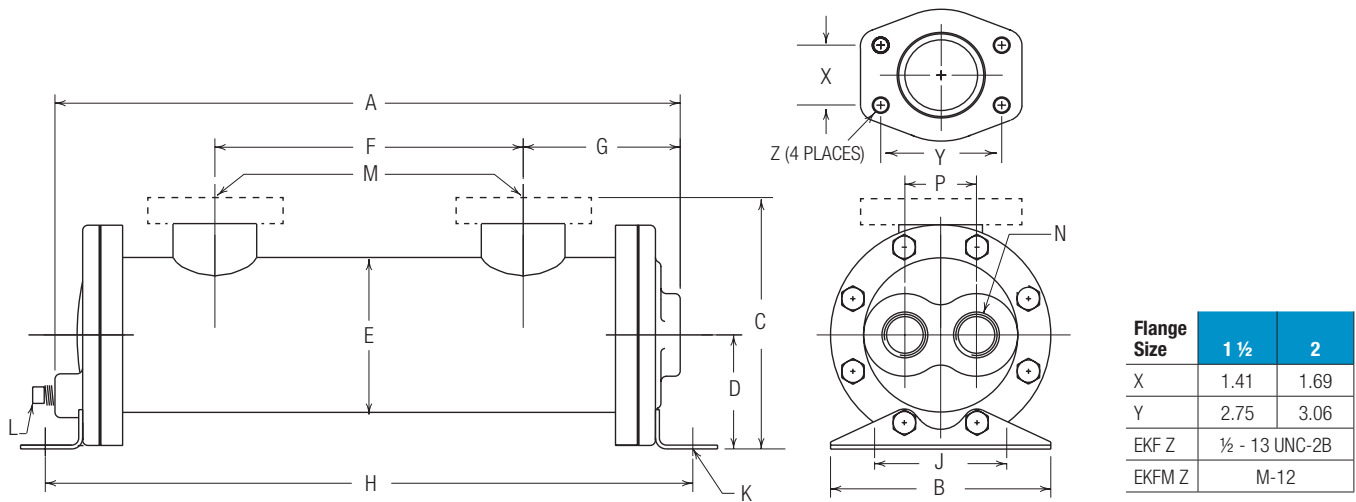

Model	A	B	C		D	E Diameter	F	G	H	J	K	L NPT BSPP	M			N NPT BSPP	P	
			NPT/BSPP/SAE	SAE Flange									NPT	SAE O-Ring	SAE Flange			BSPP
EK-505	7.37	3.5	3.74	N/A	1.62	2.55	2.19	2.59	7.44	2.50	.34 x .62 Slot	N/A	1/2	- 8 3/4-16	N/A	1/2	3/8	1.12
EK-508	10.37	3.5	3.90	N/A	1.62	2.55	3.85	3.26	10.44	2.50		N/A	3/4	- 12 1 1/16-12	N/A	3/4	3/8	1.12
EK-510	12.37	3.5	3.90	N/A	1.62	2.55	5.85	3.26	12.44	2.50		N/A	3/4		N/A	3/4	3/8	1.12
EK-512	14.37	3.5	3.90	N/A	1.62	2.55	7.85	3.26	14.44	2.50		N/A	3/4		N/A	3/4	3/8	1.12
EK-514	16.37	3.5	3.90	N/A	1.62	2.55	9.85	3.26	16.44	2.50		N/A	3/4		N/A	3/4	3/8	1.12
EK-518	20.37	3.5	3.90	N/A	1.62	2.55	13.85	3.26	20.44	2.50		N/A	3/4		N/A	3/4	3/8	1.12
EK-524	26.37	3.5	3.90	N/A	1.62	2.55	19.85	3.26	26.44	2.50		N/A	3/4		N/A	3/4	3/8	1.12
EK-536	38.37	3.5	3.90	N/A	1.62	2.55	31.85	3.26	38.44	2.50		N/A	3/4		N/A	3/4	3/8	1.12
EK-708	10.19	5.0	5.47	5.71	2.59	3.52	3.00	3.57	10.39	3.00	.44 x 1.00 Slot	1/4	1 1/2		- 24 1 1/16-12	1 1/2	1 1/2	3/4
EK-712	14.19	5.0	5.47	5.71	2.59	3.52	7.00	3.57	14.39	3.00		1/4	1 1/2	1 1/2		1 1/2	3/4	1.62
EK-714	16.19	5.0	5.47	5.71	2.59	3.52	9.00	3.57	16.39	3.00		1/4	1 1/2	1 1/2		1 1/2	3/4	1.62
EK-718	20.19	5.0	5.47	5.71	2.59	3.52	13.00	3.57	20.39	3.00		1/4	1 1/2	1 1/2		1 1/2	3/4	1.62
EK-724	26.19	5.0	5.47	5.71	2.59	3.52	19.00	3.57	26.39	3.00		1/4	1 1/2	1 1/2		1 1/2	3/4	1.62
EK-736	38.19	5.0	5.47	5.71	2.59	3.52	31.00	3.57	38.39	3.00		1/4	1 1/2	1 1/2		1 1/2	3/4	1.62
EK-1012	14.58	6.5	7.65	8.28	4.00	5.05	6.18	4.45	15.46	4.00		1/4	2	2		1 1/2	1.0	2.38
EK-1014	16.58	6.5	7.65	8.28	4.00	5.05	8.18	4.45	17.46	4.00		1/4	2	2		1 1/2	1.0	2.38
EK-1018	20.58	6.5	7.65	8.28	4.00	5.05	12.18	4.45	21.46	4.00		1/4	2	2		1 1/2	1.0	2.38
EK-1024	26.58	6.5	7.65	8.28	4.00	5.05	18.18	4.45	27.46	4.00		1/4	2	2		1 1/2	1.0	2.38
EK-1036	38.58	6.5	7.65	8.28	4.00	5.05	30.18	4.45	39.46	4.00		1/4	2	2		1 1/2	1.0	2.38
EK-1048	50.58	6.5	7.65	8.28	4.00	5.05	42.18	4.45	51.46	4.00		1/4	2	2		1 1/2	1.0	2.38

NOTE: All dimensions in inches. We reserve the right to make reasonable design changes without notice.

Dimensions

Four Pass

For 3D models and spec sheets visit the EK product page on our website.
<https://www.thermaltransfer.com/product/ek-series>

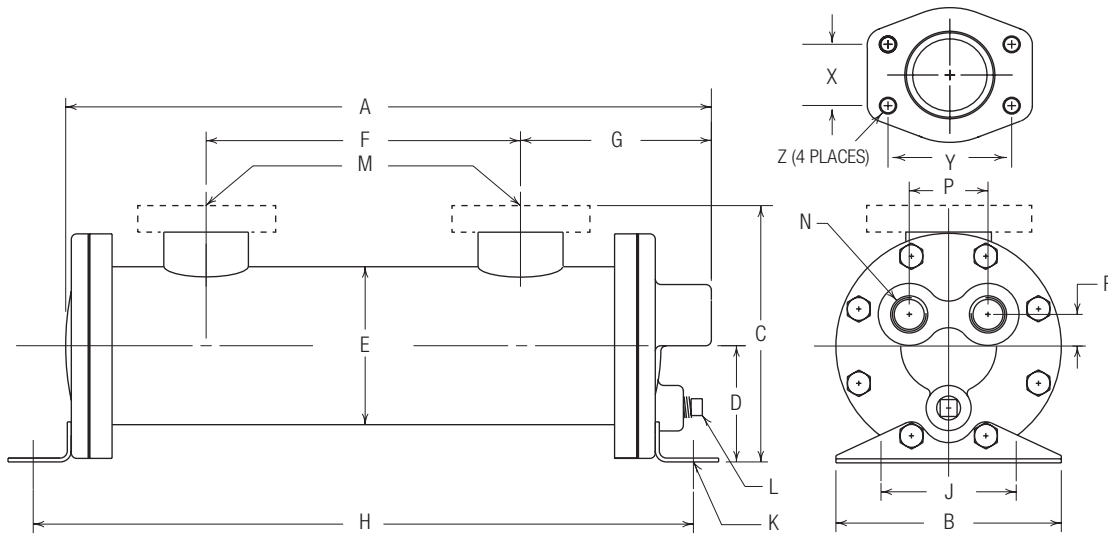

Flange Size	1 1/2	2
X	1.41	1.69
Y	2.75	3.06
EKF Z	1/2 - 13 UNC-2B	
EKFM Z	M-12	

Model	A	B	C		D	E Diameter	F	G	H	J	K	L			M			N NPT BSPP	P	R
			NPT/BSPP	SAE Flange								SAE	NPT	SAE O-Ring	SAE Flange	BSPP				
EK-708	10.37	5.0	5.47	5.71	2.59	3.52	3.00	4.25	10.39	3.00	.44 x 1.00 Slot	1/4	1 1/2	-24 1 1/8-12	1 1/2	1 1/2	1/2	1.75	.70	
EK-712	14.37	5.0	5.47	5.71	2.59	3.52	7.00	4.25	14.39	3.00		1/4	1 1/2		1 1/2	1 1/2	1/2	1.75	.70	
EK-714	16.37	5.0	5.47	5.71	2.59	3.52	9.00	4.25	16.39	3.00		1/4	1 1/2		1 1/2	1 1/2	1/2	1.75	.70	
EK-718	20.37	5.0	5.47	5.71	2.59	3.52	13.00	4.25	20.39	3.00		1/4	1 1/2		1 1/2	1 1/2	1/2	1.75	.70	
EK-724	26.37	5.0	5.47	5.71	2.59	3.52	19.00	4.25	26.39	3.00		1/4	1 1/2		1 1/2	1 1/2	1/2	1.75	.70	
EK-736	38.37	5.0	5.47	5.71	2.59	3.52	31.00	4.25	38.39	3.00		1/4	1 1/2		1 1/2	1 1/2	1/2	1.75	.70	
EK-1012	14.30	6.5	7.65	8.28	4.00	5.05	6.18	4.42	15.43	4.00		1/4	2		2	1 1/2	3/4	2.50	.89	
EK-1014	16.30	6.5	7.65	8.28	4.00	5.05	8.18	4.42	17.43	4.00		1/4	2		2	1 1/2	3/4	2.50	.89	
EK-1018	20.30	6.5	7.65	8.28	4.00	5.05	12.18	4.42	21.43	4.00		1/4	2		2	1 1/2	3/4	2.50	.89	
EK-1024	26.30	6.5	7.65	8.28	4.00	5.05	18.18	4.42	27.43	4.00		1/4	2		2	1 1/2	3/4	2.50	.89	
EK-1036	38.30	6.5	7.65	8.28	4.00	5.05	30.18	4.42	39.43	4.00		1/4	2		2	1 1/2	3/4	2.50	.89	
EK-1048	50.30	6.5	7.65	8.28	4.00	5.05	42.18	4.42	51.43	4.00		1/4	2		2	1 1/2	3/4	2.50	.89	

NOTE: All dimensions in inches. We reserve the right to make reasonable design changes without notice.